

BLACK FITTINGS

+ B-STYLE WELD-ONS	1
+ A-STYLE WELD-ONS	3



WWW.WILLOC.COM • 1.800.801.0123
2150 106TH LANE NE, BLAINE, MN 55449



BLACK STEEL BALL & SOCKET WELD-ON SET

SIZE	PART NUMBER	WEIGHT
2"	240 BWA2	1.55 lbs
3"	240 BWA3	3.35 lbs
4"	240 BWA4	7.40 lbs
5"	240 BWA5	10.70 lbs
6"	240 BWA6	14.35 lbs
8"	240 BWA8	21.95 lbs



BLACK STEEL WELD-ON BALL / MALE

SIZE	PART NUMBER	WEIGHT
2"	255 B2B	0.30 lbs
3"	255 B3B	0.50 lbs
4"	255 B4B	1.45 lbs
5"	255 B5B	1.95 lbs
6"	255 B6B	2.25 lbs
8"	255 B8B	4.30 lbs



BLACK STEEL WELD-ON SOCKET / FEMALE

SIZE	PART NUMBER	WEIGHT
2"	257 S2B	0.25 lbs
3"	257 S3B	0.55 lbs
4"	257 S4B	1.65 lbs
5"	257 S5B	2.50 lbs
6"	257 S6B	3.00 lbs
8"	257 S8B	5.75 lbs



BLACK LOCKING LEVER RING

SIZE	PART NUMBER	WEIGHT
2"	274 LR2B	1.00 lbs
3"	274 LR3B	2.20 lbs
4"	274 LR4B	4.30 lbs
5"	274 LR5B	6.25 lbs
6"	274 LR6B	9.10 lbs
8"	274 LR8B	12.90 lbs

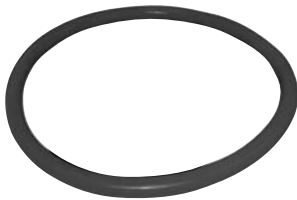

OIL RESISTANT O-RING

SIZE	PART NUMBER	WEIGHT
2"	285 OR2R	0.05 lbs
3"	285 OR3R	0.10 lbs
4"	285 OR4R	0.20 lbs
6"	285 OR6R	0.45 lbs
8"	285 OR8R	0.55 lbs

PRICE AND DISCOUNT STRUCTURES SUBJECT TO CHANGE WITHOUT NOTICE.

VACUUM RATING
30 inches hg

PRESSURE RATING
2 & 3 inch = 290 psi
4 – 8 inch = 175 psi

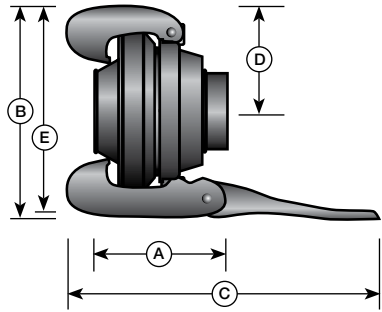

WELD-ON SET SPECS

Hose Set Specifications to 1/100th of an inch // Specs Subject to Change

SIZE	A	B	C	D	E
2"	2.68	6.10	7.09	3.35	4.92
3"	3.43	7.87	9.25	3.54	7.09
4"	5.28	11.81	10.83	6.69	9.25
5"	4.69	11.22	11.42	5.51	10.83
6"	4.84	12.60	13.50	6.30	11.81
8"	6.30	15.35	13.50	9.06	13.98

PRICE AND DISCOUNT STRUCTURES SUBJECT TO CHANGE WITHOUT NOTICE.

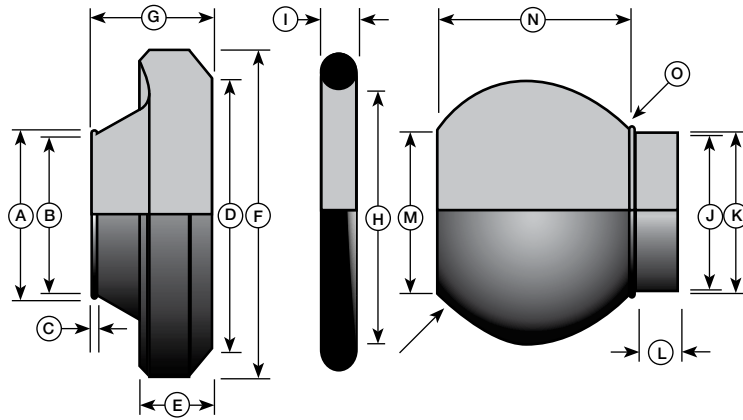

WELD-ON SPECS

Hose Set Specifications to 1/100th of an inch // Specifications Subject to Change







SIZE	A	B	C	D	E	F	G	H	I	J
2"	2.01	1.91	0.24	2.83	0.67	3.27	1.22	2.44	0.37	1.91
3"	3.07	2.99	0.28	3.86	0.87	4.57	1.46	3.48	0.51	2.99
4"	4.37	4.25	0.47	5.79	1.10	6.50	2.32	5.20	0.59	4.25
5"	5.39	5.20	0.47	6.42	1.34	7.52	2.13	5.98	0.71	5.20
6"	6.42	6.22	0.59	7.17	1.34	8.31	2.05	6.69	0.75	6.22
8"	7.95	7.64	0.71	9.09	1.34	10.51	2.99	8.66	0.75	7.64
SIZE	K	L	M	N	O					
2"	2.01	0.28	1.97	2.17	2.76					
3"	3.07	0.55	3.19	2.87	3.86					
4"	4.37	0.59	4.41	4.21	5.71					
5"	5.39	0.67	5.39	3.78	6.26					
6"	6.42	0.75	6.10	4.06	7.09					
8"	7.87	0.67	7.87	5.00	9.06					

WIL - 102108

© 2008 WIL-LOC

TECH TIP

Virtually any plumbing configuration may be fabricated using the Wil-loc carbon steel weld-on fittings. Please check columns A & K for correct pipe sizing. IPSO and ODA pipe may be used with steel weld-on fittings. When fabricating customized fittings, ensure there is enough length for the locking levers to fully close without restriction. The minimum shank lengths are given on the flange specifications pages of this catalog.

	SIZE	PART NUMBER	WEIGHT
	BLACK STEEL BALL & SOCKET WELD-ON SET		
	10"	241 BWA10	32.55 lbs
	12" Galvanized Locking Bar sold separately.		
	BLACK STEEL BALL & SOCKET WELD-ON SET		
	12"	241 BWA12	60.35 lbs
	12" Galvanized Locking Bar sold separately.		
	BLACK STEEL WELD-ON SOCKET / FEMALE		
	10"	258 S10B	14.70 lbs
	BLACK STEEL WELD-ON SOCKET / FEMALE		
	12"	258 S12B	30.30 lbs
	12" Galvanized Locking Bar sold separately.		
	BLACK STEEL WELD-ON BALL / MALE		
	10"	256 B10B	10.00 lbs
	12"	256 B12B	16.80 lbs
	BLACK STEEL WELD-ON LOCKING RING		
	10"	259 B10R	7.85 lbs
	12"	259 B12R	13.25 lbs
O-Ring sold separately.			
	OIL RESISTANT O-RING		
	10"	286 OR10R	1.05 lbs
	12"	286 OR12R	1.55 lbs

PRICE AND DISCOUNT STRUCTURES SUBJECT TO CHANGE WITHOUT NOTICE.

VACUUM RATING
30 inches hg

PRESSURE RATING
88 psi

NOTE
12" locking rings come with removable locking bar

WELD-ON SET SPECS
Specs to 1/100th of an inch

SIZE	A	B	C
10"	9.06	20.08	15.35
12"	10.24	24.21	10.43

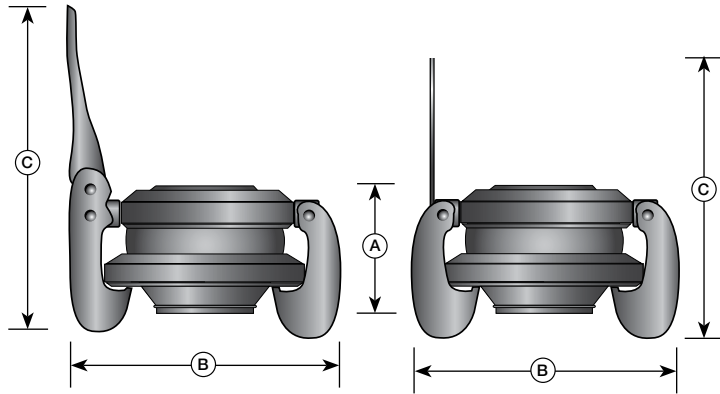

PRICE AND DISCOUNT STRUCTURES SUBJECT TO CHANGE WITHOUT NOTICE.

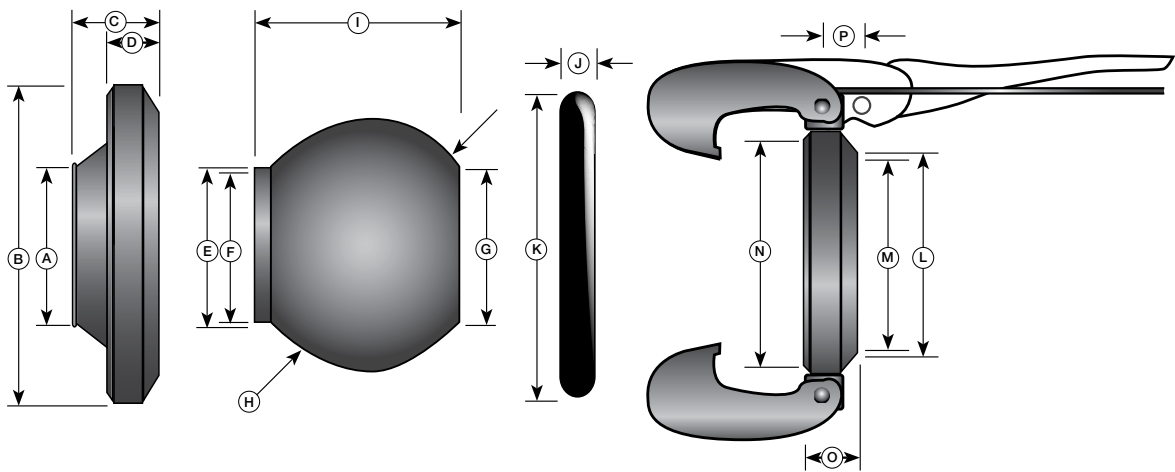

WELD-ON SPECS

Specifications to 1/100th of an inch // Specifications subject to change

SIZE	A	B	C	D	E	F	G	H	I	J
10"	11.14	14.09	2.40	1.42	9.57	9.25	9.96	11.81	6.73	0.86
12"	13.35	17.56	2.76	1.69	12.01	11.65	11.97	14.57	8.35	0.93
SIZE	K	L	M	N	O	P				
10"	11.06	9.72	9.37	11.89	4.33	1.38				
12"	13.98	12.20	11.85	14.65	4.92	1.65				

TECH TIP

For applications that prohibit use of hot-dipped galvanized pipe and fittings, Wil-loc black weld-ons and o-rings may be specially plated or coated to fit your needs. Epoxy-painted, zinc-plated and fused-Teflon coatings are available.

Before welding, check to make sure locking ring can slide over the O.D. of your pipe. If not, place locking ring over the pipe and weld the male fitting onto the end of the pipe.

